



ACCESS ALL AREAS WITH  
**AERIAL PLATFORMS**

## ABOUT HYVA

Founded in 1979, Hyva now operates in more than 130 countries with over 2,500 employees around the world. The Hyva Group, encompasses 37 subsidiaries globally, with an extraordinary sales and service coverage and 12 production facilities in Brazil, China, Germany, India, and Italy, with more than 25,000 customers.

In 2017 we reached a production landmark with the production of our two millionth hydraulic telescopic cylinder. Today Hyva cylinders work around the world to satisfy our customer demands in new applications, existing and new geographical territories under various weather conditions, confirming Hyva as the world leader in the production of telescopic cylinders.







## STEP ABOARD HYVA'S AERIAL PLATFORM

Hyva's Aerial Platforms give you the access that you need to carry out a variety of above ground tasks. And, as you would expect, their accuracy, stability and efficiency provide all the requirements in order to work well and safely at height.

We supply and support a broad range of truck-mounted aerial platforms, suited to a multitude of applications in many industries. Applications range from lifting materials for construction through cleaning of facades and external glass, to landscaping and greenery maintenance.

Our product range includes telescopic systems (AT) for situations where strong rigidity is required and simple functionality is adequate, and, articulated systems (AZ) for situations where more flexibility of movement and versatility in applications is required.

Aerial Platforms are part of the Hyva product portfolio which also includes Tipping Solutions, Container Handling, Waste Handling and Cranes. Together, these products offer a one-stop-shop solution for lifting, loading, handling, moving and access.

Products are sold worldwide and maintained and serviced through a network of dealers and agents.

Our experienced international sales and after-sales teams from our own subsidiaries and a vast network of service partners and dealers are dedicated and empowered to provide world-class customer support through our Hyva Service and Maintenance Care Programmes. Our maintenance programmes can be customised to your needs with repair and maintenance contracts at local service workshops worldwide

**We have the answers, just ask us the questions.**

# APPLICATIONS - OUR PLATFORMS AT WORK

Hyva access platforms are typically used to carry out installation, fitting, fixing, repair, maintenance and cleaning tasks in a variety of applications and industry sectors. This can range from fixing steel structures on a sports stadium, to conducting maintenance on a wind turbine, or, maintaining greenery in a municipal park.

Accuracy, stability and efficiency are essential to optimising time and task and working safely at height. And, in some tasks, additional features such as compactness for restricted spaces on the road or on the works site; absolute verticality to allow “plumb line movements”; increased lifting capacity to support two operators and equipment; stability over rough terrain; and easily passes obstacles and can operate in difficult to reach areas, are also advantageous.

Hyva's AZ (articulated platforms, working height 14-29 metres) and AT (telescopic platforms, working height 15-28 metres) ranges meet these requirements and are well suited to a wide variety of applications.



**CONSTRUCTION**

Masonry work, Materials handling, Roofing and guttering, Window fitting, Events and trade shows.



**INDUSTRY**

Machinery building and cleaning, Elevator installation, lighting maintenance, Wind turbine installation and maintenance, Underbridge maintenance, Telecom masts.



**BUILDING MAINTENANCE**

Roofing and guttering, Cleaning facades and external glass, Renovation and restoration, Interior maintenance and decoration, Painting.



**GOVERNMENT**

Emergency services, Municipalities, Military.



**LIGHTING AND SIGNAGE**

Street lamps, Decorative lighting, Hanging signs, Installation and maintenance.



**RENTAL**

End users may buy aerial platforms directly or experience them through Rental where they find Hyva's range to be safe, easy to use, with simple and intuitive controls and compact for easy handling.



**AGRICULTURE**

Landscaping, Greenery maintenance, Access to silos, Tree pruning/removal.



**OTHER APPLICATIONS**

Airports, Ports, Mining, Oil & Gas.



## BUILDING OUR AERIAL SOLUTIONS

Hyva's aerial platforms are the product of technical expertise and experience built over many years of design, development and production to the highest quality standards in components and processes.



### Compact Design

The design of our platforms has been perfected to enable access and transit even in confined spaces, thanks to its extreme compactness.



### Clean top boom

The boom design ensures the protection of electrical and hydraulic systems. Both the extension cylinder and the electrical and hydraulic systems are contained inside the boom arm, protected from weathering and debris. This prevents them getting caught up with other elements during operation, minimises the risk from damage from weather (rain, cold, heat, snow) and debris (lime, paint, branches, etc.), and, reduces maintenance costs.



### Lifting capacity

Increased to allow two operators with equipment to work at height.

### Interchangeable basket

Available in aluminium and glass fibre. Standard capacity 200-250kg, some models can provide 300 to 400kg basket lift capacity.



## Up and over

The articulated booms have been designed to have optimal passing over barriers or walls and allows easy access to reach areas beyond.



## Stability

The boom design ensures full stability at height for the operator in the basket. Variable stabilisation in the jacking system ensures stability over rough terrain. Narrow jacking stabilisation allows the platform to be positioned in congested areas which otherwise would be difficult to access. All machines are tested for stability at height.



## Build strength

The special design of the boom and the use of SSAB Strenx – a high-strength, high-performance structural steel – makes platforms stronger, lighter and more sustainable. Design incorporating this specialist steel ensures rigidity and stability at height in the working phase, enabling the user to work in perfect safety.



## Controls

A newly designed control panel, with its unique angle and cover panel, protects terminal commands and prevents damage from external agents. And, with the double control panel, with proportional controls, the same functions are available in basket and on the ground.

Ergonomic analysis is conducted at the concept design stage to ensure ease of use for control panels.

## AT-Range

- Single telescopic boom, telescopic extension and pivoted basket.
- Where strong rigidity is required and simple functionality is adequate.
- Compact design and working positions, ideal for town environments.

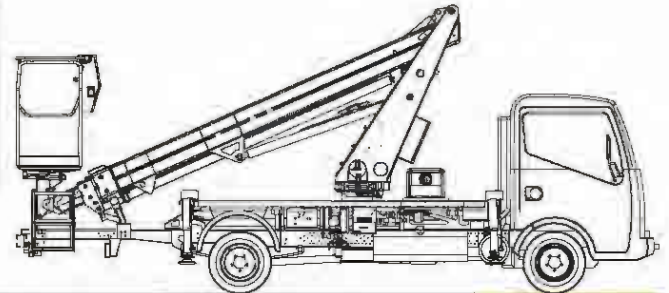

### Specifications

Telescopic boom (main boom + 1-3 telescopic extensions)

AT-model						MIN. TRUCK GVW	MARKET	
	Working height	Platform height	Outreach	Capacity	Basket dim.		CE	NO CE
AT15	15 m	13 m	9 m	250 kg	1400x700x1100 mm	5 t		✓
AT17	16.6 m	14.6 m	5.9 / 11.3 m	250 / 80 kg	1400x700x1100 mm	5 t		✓
AT18	18 m	16 m	9 m	250 kg	1400x700x1100 mm	5.5 t		✓
AT20	20 m	18 m	8.4 / 9.2 / 13.3 m	300 / 250 / 80 kg	1400x700x1100 mm	5.5 t		✓
AT23	23 m	21 m	6.5 / 7.2 / 11.3 m	300 / 250 / 80 kg	1400x700x1100 mm	5.5 t		✓
AT28	28.5 m	26.5 m	13 / 14.5 / 17 m	400 / 300 / 120 kg	1720x700x1100 mm	16 t		✓
AT17	16.6 m	14.6 m	5.9 / 11.3 m	250 / 80 kg	1400x700x1100 mm	3.5 t	✓	
AT18	18 m	16 m	11.8 / 13 m	300 / 120 kg	1400x700x1100 mm	3.5 t	✓	
AT20J	19.8 m	17.8 m	12 / 14.7 m	300 / 120 kg	1400x700x1100 mm	3.5 t	✓	
AT27	27 m	25 m	10 / 12.5 m	250 / 100 kg	1400x700x1100 mm	3.5 t	✓	

## AZ-Range

- Single or double articulated boom, telescopic extension and pivoted basket.
- Where more flexibility of movement and versatility in applications is required.
- Easy-to-use, versatile, ideal for maximum performance in many different applications.

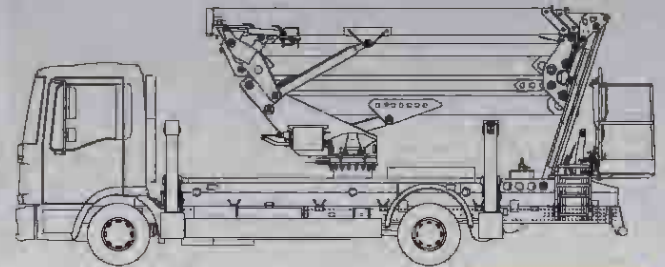

### Specifications

Articulated double or simple parallelogram boom + telescopic

AZ-model						MIN. TRUCK GVW	MARKET	
	Working height	Platform height	Outreach	Capacity	Basket dim.		CE	NO CE
AZ14.2	14 m	12 m	5.7 m	230 kg	1400x700x1100 mm	5 t		✓
AZ15.2	15 m	13 m	6.2 m	230 kg	1400x700x1100 mm	5 t		✓
AZ20	19.8 m	17.8 m	9.5 m	200 kg	1400x700x1100 mm	5.5 t		✓
AZ20.3	20 m	18 m	8.8 m	200 kg	1400x700x1100 mm	5 t		✓
AZ21J	20.6 m	18.6 m	9.6 m	250 kg	1400x700x1100 mm	5.5 t		✓
AZ23J	22.7 m	20.7 m	10 m	230 kg	1400x700x1100 mm	6 t		✓
AZ25	24.6 m	22.6 m	11.7 m	230 kg	1400x700x1100 mm	6.5 t		✓
AZ26	25.5 m	23.5 m	12 m	200 kg	1400x700x1100 mm	8.5 t		✓
AZ26J	26 m	24 m	14 m	230 kg	1800x700x1100 mm	9 t		✓
AZ29	29 m	27 m	15 m	250 kg	1400x700x1100 mm	12 t		✓
AZ29J	28.7 m	26.7 m	15.5 m	230 kg	1800x700x1100 mm	14 t		✓
AZ20.3	20 m	18 m	8.8 m	200 kg	1400x700x1100 mm	3.5 t	✓	
AZ20.3H	20 m	18 m	8.8 m	200 kg	1400x700x1100 mm	3.5 t	✓	
AZ21.33H	20.6 m	18.6 m	9.6 m	250 kg	1400x700x1100 mm	3.5 t	✓	
AZ23.33H	22.6 m	20.6 m	10 m	230 kg	1400x700x1100 mm	3.5 t	✓	
AZ25HV	24.6 m	22.6 m	11 m	230 kg	1400x700x1100 mm	3.5 t	✓	
AZ26J	26 m	24 m	14 m	230 kg	1800x700x1100 mm	6 t	✓	
AZ29J	28.7 m	26.7 m	15.5 m	230 kg	1800x700x1100 mm	10.5 t	✓	



## AZ Pick Up-Range

- Where there are confined spaces with limited access conditions and compact solutions are required.

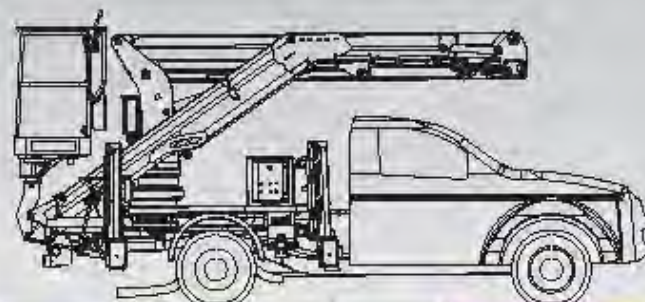

### Specifications

Articulated double or simple parallelogram boom + telescopic

AZ-Pick Up model						MIN. TRUCK	MARKET	
	Working height	Platform height	Outreach	Capacity	Basket dim.	GVW	CE	NO CE
AZ13	13 m	11 m	6.5 m	200 kg	1300x700x1100 mm	3.5 t		✓
AZ15.2	14.7 m	12.7 m	6.3 m	230 kg	1400x700x1100 mm	3 t	✓	





**130 countries**  
**2,500 employees**  
**25,000 customers**  
**37 subsidiaries**  
**12 production facilities**



**Hyva is a leading provider of innovative and highly efficient transport solutions for commercial vehicles used in transport, construction, mining, materials handling and environmental service industries.**

**Founded in 1979 in the Netherlands, the company has a global presence with 37 fully owned subsidiaries, extraordinary service coverage and 12 manufacturing facilities in Brazil, China, Europe and India.**

For more information on Hyva, please visit [www.hyva.com](http://www.hyva.com)

or follow us on:



**Hyva Holding B.V.**  
Antonie van Leeuwenhoekweg 37  
2408 AK Alphen aan den Rijn  
The Netherlands  
Telephone: +31 (0)172 - 42 35 55  
Telefax: +31 (0)172 - 42 08 80  
[info@hyva.com](mailto:info@hyva.com)  
[www.hyva.com](http://www.hyva.com)



Quality and  
environmental certified

DEALER STAMP